

JVC®

The Perfect Experience / —
/

1/3" CCD COLOR VIDEO CAMERA **TK-C920U**

(24V AC/12V DC)

Revolutionary High Resolution Camera
with Super LoLux Sensitivity

0.7 Super LoLux™
lux



Shown with
optional lens.

535 TV Lines



Conventional Camera

- 1/3" High Resolution CCD with 380,000 Active Pixels
- 535 TVL Resolution
- Super-LoLux Sensitivity: 0.7 lux F1.2
- Signal-to-Noise Ratio: 50dB (AGC OFF)
- Revolutionary Integrated 10-bit Digital Signal Processor
- Full-Featured Security Camera
 - Automatic Electronic Shutter (AES) Mode ON/OFF

- Automatic Gain Control (AGC) ON/OFF Switching
- White Balance — Automatic Tracking and Manual Modes
- Back-Light Compensation — ON/OFF
- Sync Systems — INT/Line Lock Switching
- Supports Video/DC Iris Lenses
- C/CS Lens Compatible
- Ultra Compact Camera Body
- 24V AC/12V DC Power Supply

JVC's revolutionary 535 TVL CCD and leading edge DSP technology combine to meet future market needs.

JVC not only satisfies customers' current demands but also anticipates their future requirements by incorporating advanced camera technologies inside the TK-C920U high resolution, color surveillance camera.

The camera performs brilliantly in all the key areas. 535 TVL resolution is delivered by the 1/3" Interline Transfer CCD. The quality of key image parameters are continually optimized by the intelligent Digital Signal Processor. The Super LoLux function allows the camera to achieve reliable, high performance pictures even at light levels as low as 0.7 lux (using an F1.2 lens).

Built-in Revolutionary Digital Signal Processor (DSP)

JVC's innovative Digital Signal Processor automatically adjusts camera parameters to ensure sharp and natural pictures of 535 TV lines horizontal resolution with high-quality performance.

1/3-inch CCD with 380,000 Effective Pixels

JVC'S TK-C920U comes with a 1/3-inch Interline Transfer (IT) CCD for accurate color reproduction and super LoLux sensitivity of 0.7 lux F1.2.

Signal-to-Noise Ratio of 50dB (AGC Off)

The TK-C920U's sharp, high resolution picture also achieves a signal-to-noise ratio of 50dB.

Super LoLux and Automatic Gain Control (AGC)

As the ambient light level falls the AGC seamlessly increases the camera's sensitivity. With Super LoLux turned on the AGC will further increase the camera's sensitivity to 0.7 lux at F1.2.

Manual or Automatic (ATW) White Balance

For flexibility of operation in a wide range of environments the white balance can be set manually or can be automatically adjusted in real time by the Automatic White Tracking function over a range of 2,300°K to 10,000°K.

Specifications

| | |
|-------------------------------|--|
| Signal system | NTSC |
| Pickup device | 1/3" Interline-Transfer CCD (with complementary color filter) |
| Number of effective pixels | 380,000 (768 H x 494 V) |
| Video Processing | Built-in DSP (10 bits) |
| Pickup area | 4.8 mm (H) x 3.6 mm (V) |
| Sync system | Internal, Line Lock (60Hz regions only) |
| Scanning system | 2:1 interlaced, 525 lines |
| Scanning frequency | 15.734kHz (H); 59.94Hz (V) |
| Video output | Composite video signal: 1.0 V(p-p), 75 ohms |
| Video S/N | 50 dB (AGC OFF) |
| Horizontal resolution | 535 TV lines (typical) |
| Minimum required illumination | 0.7 lux (F1.2, AGC ON) — Video level 25% |
| Iris control | Video iris/DC iris |
| White balance | ATW/Manual |
| BLC | ON and OFF |
| AES | ON and OFF (1/60 — 1/100,000 sec.) |
| Lens mount | C/CS |
| Power requirement | AC 24V (60Hz), DC 12V |
| Power consumption | 4.7W |
| Operating temperature range | 18°F to 90°F 32°F to 72°F (recommended) |
| Weight | 0.82 lbs. (370g) |

Controls, connectors and indicators



- 1 BACK FOCUS locking screw
- 2 BACK FOCUS adjustment and C/CS mount selector ring
- 3 Lens mount (C or CS)
- 4 Camera mounting bracket
- 5 IRIS connector
- 6 VIDEO/DC IRIS switch
- 7 LEVEL volume
- 8 AUTOMATIC GAIN CONTROL switch
- 9 AES (Automatic Electronic Shutter) switch
- 10 BACK LIGHT COMPENSATION switch
- 11 WHITE BALANCE select switch
- 12 LL/INT select switch
- 13 PHASE/W.B. select switch
- 14 PHASE/W.B. adjustment switch
- 15 RESET button
- 16 Power indication

Dimensions

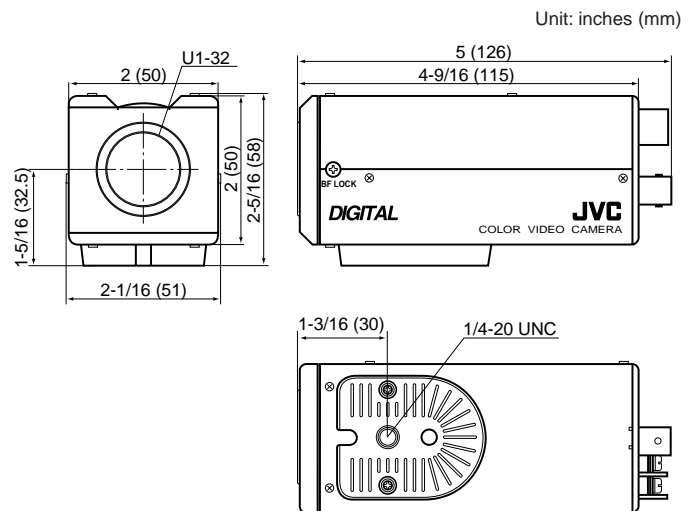

Design and specifications subject to change without notice.

JVC®

DISTRIBUTED BY

JVC PROFESSIONAL PRODUCTS COMPANY
DIVISION OF JVC AMERICAS CORP.
1700 Valley Road, Wayne, N.J. 07470
TEL: (973) 317-5000, (800) 582-5825
FAX: (973) 317-5030
Internet Web Site <http://www.jvc.com/pro>
E-mail: proinfo@jvc.com

JVC CANADA INC.
21 Finchdene Square, Scarborough, Ontario M1X 1A7
TEL: (416) 293-1311 FAX: (416) 293-8208
Internet Web Site <http://www.jvcpro.com/>



■ The Hachioji Plant of Victor Company of Japan, Ltd., has received ISO14001 and ISO9001 Certifications under the global standard for environmental management.

Printed in Japan
KCN-1816 CETKC920UKN0309